

HJ series

Rugged hand grip controllers •
non-contacting Hall effect technology



DISTINCTIVE FEATURES

- Rugged, multi-axis control
- CAN bus J1939 & CANopen options
- USB output options
- Several handle options
- 5 million lifecycles



ENVIRONMENTAL SPECIFICATIONS

- Operating Temperature: -40 °C to +85 °C (-40 °F to +185 °F)
- Storage Temperature: -40 °C to +85 °C (-40 °F to +185 °F)
- Above Panel Sealing: Up to IP63 (subject to final specifications)*
- EMC Immunity Level: EN61000-4-8: 2009
- EMC Emissions Level: EN61000-4-3:2006
- ESD: EN61000-4-2: 2008



SENSOR SPECIFICATIONS

- Technology: Hall effect sensors, single or dual
- Supply Voltage Range: 5.00 VDC \pm 0.01VDC
- Ratiometric output voltage: See output options
- Reverse Polarity max: -10 VDC
- Transient overvoltage max: 16 VDC
- Minimum load: 1K Ω
- Return to center voltage tolerance (no load): \pm 200mV



MECHANICAL SPECIFICATIONS

- Operating Force: 14.0N (3.10 lbf)
- Maximum Vertical Impact: 34.5J
- Maximum Horizontal Load: 200 lbf at 8 inches above panel
- Mechanical Angle of Movement: 38° (subject to limiter plate)
- Expected Life: 5 million cycles
- Mass/Weight: 544.3g (19.2 oz) typical
- Lever Action (centering): Spring

* Ball tip handle rated up to IP67

The company reserves the right to change specifications without notice.



HJ series

Rugged hand grip controllers •
non-contacting Hall effect technology



MATERIALS

- Body: Glass filled nylon
- Handles: Glass filled nylon
- Boot: Silicone

APEM products may be recycled at end-of-life for the reclaiming of valuable recyclable components.



MOUNTING

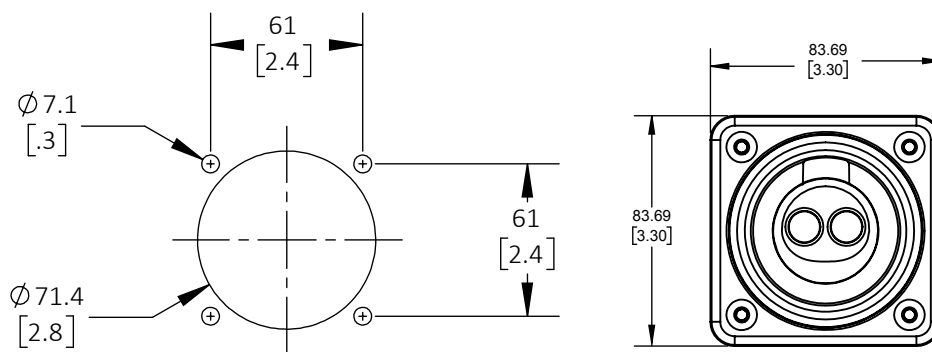

VOLTAGE OUTPUT OPTIONS¹

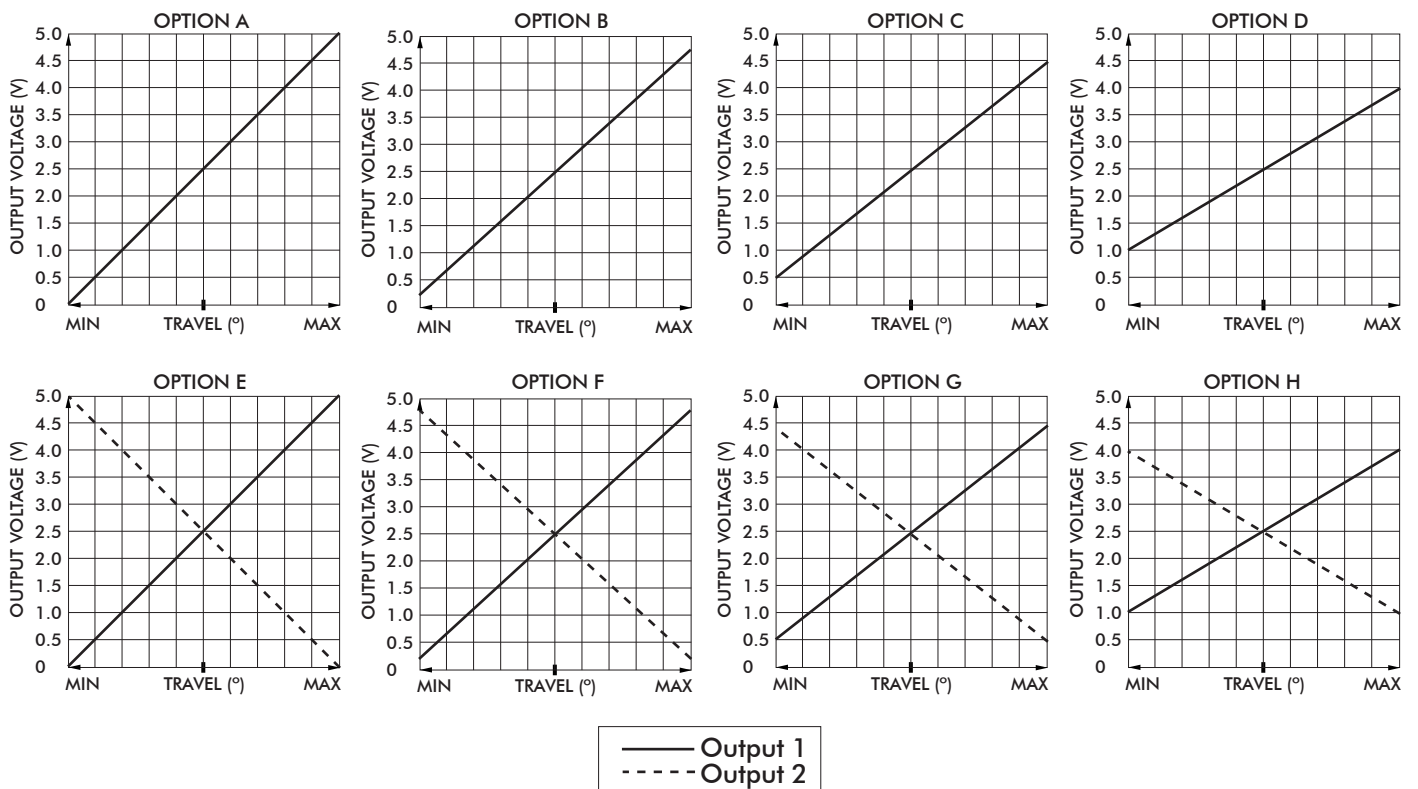

¹ Voltage outputs are ratiometric to supply voltage

Rugged hand grip controllers • non-contacting Hall effect technology



OUTPUT OPTIONS

CAN bus J1939

APEM's HJ CAN bus joysticks conform to the SAE J1939 serial bus specification used for communications between electronic control units and vehicle components. The HJ CAN bus option provides I/O extension for up to 24 digital and 11 analog inputs.

ELECTRICAL SPECIFICATIONS	
• Supply Voltage:	6VDC to 35 VDC
• Supply Current:	15mA min, +5mA per LED, +10mA per axis
WIRING SPECIFICATION	
• Red Wire:	Supply Power
• Black Wire:	Ground
• Green Wire:	CAN high data
• White Wire:	CAN low data
• Blue Wire:	Identifier Select LSB
• Orange Wire:	Identifier Select MSB
ENVIRONMENTAL	
• Operating temperature:	-40°C to +85°C (-40°F to +185°F)
• Storage temperature:	-40°C to +85°C (-40°F to +185°F)

CONNECTOR OPTIONS:

- Cable assembly with Deutsch DTM04 style plugs

CAN bus CONFIGURATION:

- Contact Technical Support for assistance

CANopen

- Contact Technical Support for assistance with CANopen configuration.

USB

Featuring USB 2.0 HID compliant interface, APEM's USB joysticks are recognized as standard HID "game controller" devices. Adhering to the HID specification, APEM's USB joysticks are plug-and-play with most versions of Windows. Joystick button and axis assignments are dependent upon the controlled application.

FEATURES:

- USB 2.0 HID compliant "game controller" device
- Easy to install and operate
- Functions determined by controlled application

SUPPLIED WIRING

USB: USB Male Type A Connector with overmolded cable

CURSOR EMULATION

The Cursor Emulation option converts a multi-axis joystick into a mouse, cursor control or "pointing device".

APPLICATIONS

The Cursor Emulation option is ideal for vehicle applications subjected to dirt and high vibration which makes operating a traditional cursor control device difficult. The Cursor Emulation option is widely used in shipboard and military applications.

FEATURES:

- HID compliant "pointing device"
- Plug-and-play with USB option

SUPPLIED WIRING

USB: USB Male Type A Connector with overmolded cable

HJ series

Rugged hand grip controllers •
non-contacting Hall effect technology



OUTPUT OPTIONS

Voltage Regulator

The Voltage Regulator allows APEM's Hall effect joysticks to operate with a range of supply voltages.

Voltage regulator, unipolar

Supply Voltage Range: 6-35 VDC

Output Voltage Range: 0-5 VDC

Voltage regulator, bipolar

Supply Voltage Range: 11-35 VDC

Output Voltage Range: ± 10 VDC

HJ series

Rugged hand grip controllers • non-contacting Hall effect technology



BUILD YOUR PART NUMBER

HJ	SG				
SERIES	HANDLE	AXIS	LIMITER PLATE	SPRING	OUTPUT OPTIONS
	SG Stock Grip Handle	A One B Two	S Square R Round P + Limiter X X axis only Y Y axis only G Guided feel - Square H Guided feel - Round	A Standard	A 0V - 5V B 0.25V - 4.75V C 0.5V - 4.5V D 1V - 4V E (0 - 5V) (5 - 0V) F (0.25V - 4.75V) (4.75V - 0.25V) G (0.5V - 4.5V) (4.5V - 0.5V)
					H (1V - 4V) (4V - 1V) N CAN bus J1939 P CANopen U USB Joystick Game Controller T USB Mouse Cursor Control V Voltage regulator Unipolar Y Voltage regulator Bi-polar (± 10 VDC)

		A
HANDLE	SEALING	
A No pushbutton B One top pushbutton C Two top pushbuttons D Top rocker switch (mom-off-mom) E Two top pushbuttons two side pushbuttons F Operator presence switch G One top pushbutton & operator presence switch H Two top pushbuttons & operator presence switch J Operator presence switch & protective silicone boot K One top pushbutton, operator presence switch & protective silicone boot	E Up to IP63 (above panel)* N None	*Above panel sealing up to IP63 (dependent on handle configuration)

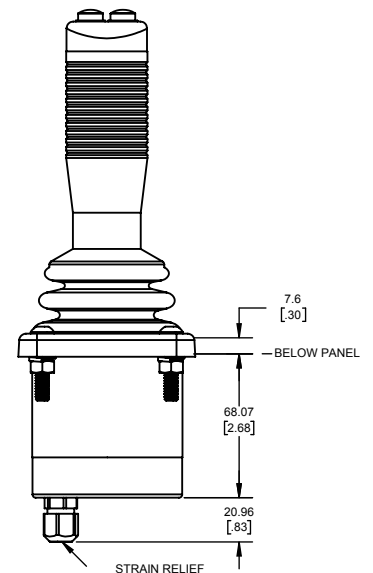
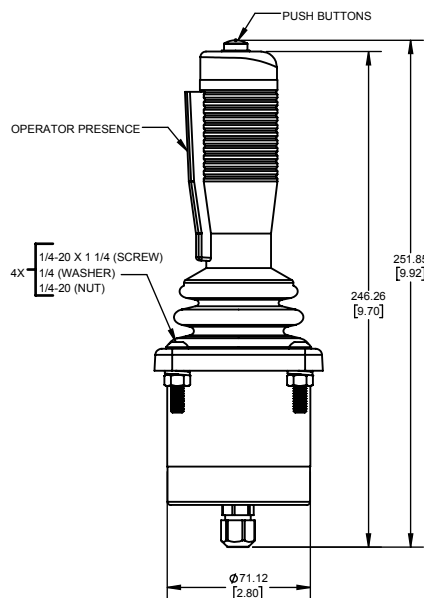

HJ series

Rugged hand grip controllers •
non-contacting Hall effect technology



HANDLE OPTIONS - STOCKGRIP (SG)

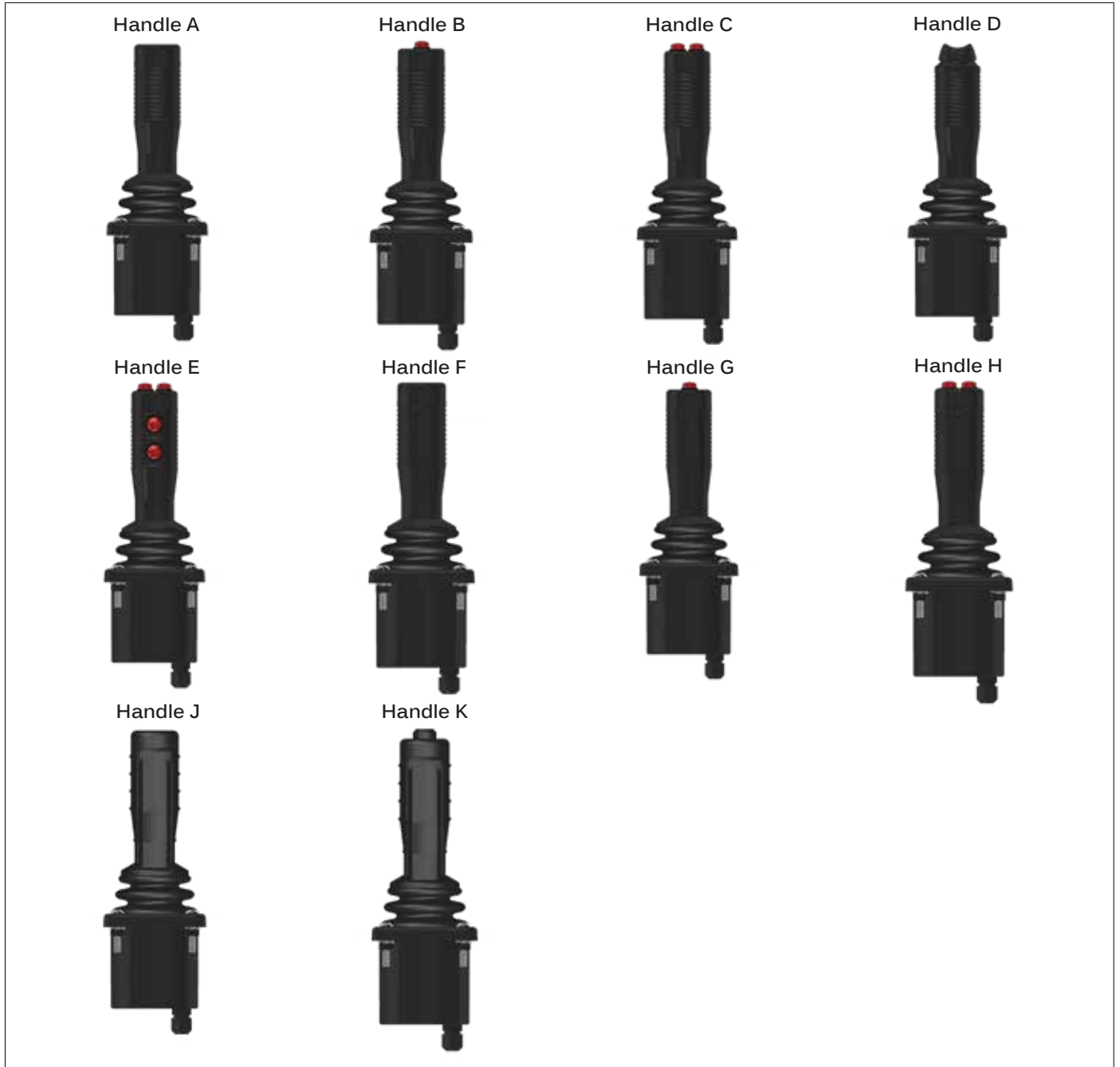

PUSHBUTTON SPECIFICATONS

ELECTRICAL RATINGS: @ 28VDC or 115VAC, 60/400Hz

Resistive: 5A

Inductive: 3A

DWV: 1050Vrms

ELECTRICAL LIFE: 25,000 cycles

MECHANICAL LIFE: 1,000,000 cycles

OPERATING TEMP:

OPERATING FORCE:

MATERIALS:

Case:

Actuator:

Terminals:

-40°C to +85°C (-40°F to 185°F)

1.7lbs. ± 0.5lb.

Thermoplastic

Thermoplastic

Brass with gold over silver

HJ series

Rugged hand grip controllers •
non-contacting Hall effect technology



BUILD YOUR PART NUMBER

SERIES	HANDLE	AXIS	LIMITER PLATE	SPRING	OUTPUT OPTIONS	SEALING
HJ	BT Ball Tip Handle	A One B Two	S Square R Round P + Limiter X X axis only Y Y axis only G Guided feel - Square H Guided feel - Round	A Standard	A 0V - 5V B 0.25V - 4.75V C 0.5V - 4.5V D 1V - 4V E (0 - 5V) (5 - 0V) F (0.25V - 4.75V) (4.75V - 0.25V) G (0.5V - 4.5V) (4.5V - 0.5V) H (1V - 4V) (4V - 1V) N CAN bus J1939 P CANopen U USB Joystick Game Controller T USB Mouse Cursor Control V Voltage regulator Unipolar Y Voltage regulator Bi-polar (± 10 VDC)	E Up to IP67 (above panel) N None

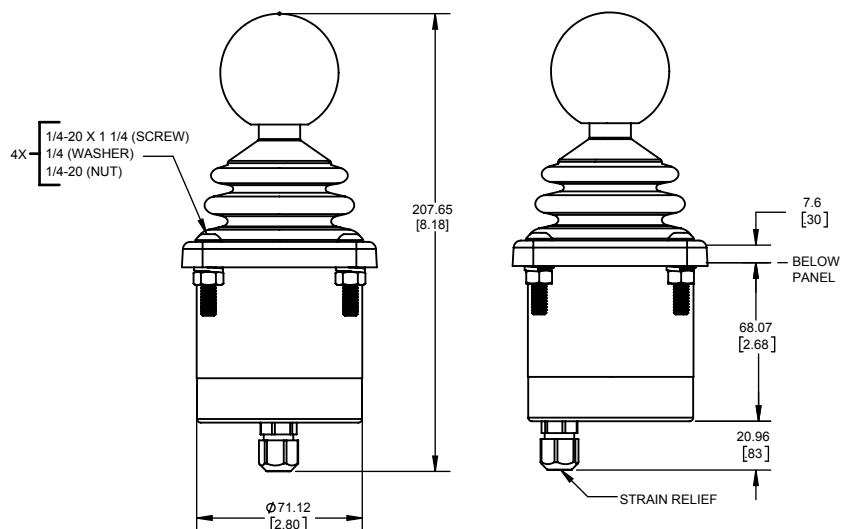

HJ series

Rugged hand grip controllers • non-contacting Hall effect technology

BUILD YOUR PART NUMBER

HJ	SH																																
SERIES	HANDLE	AXIS	LIMITER PLATE	SPRING	OUTPUT OPTIONS																												
	SH Short Stock Grip	A One B Two	S Square R Round P + Limiter X X axis only Y Y axis only G Guided feel - Square H Guided feel - Round	A Standard	<table border="1"> <tr><td>A</td><td>0V - 5V</td><td>H</td><td>(1V - 4V) (4V - 1V)</td></tr> <tr><td>B</td><td>0.25V - 4.75V</td><td>N</td><td>CAN bus J1939</td></tr> <tr><td>C</td><td>0.5V - 4.5V</td><td>P</td><td>CANopen</td></tr> <tr><td>D</td><td>1V - 4V</td><td>U</td><td>USB Joystick Game Controller</td></tr> <tr><td>E</td><td>(0 - 5V) (5 - 0V)</td><td>T</td><td>USB Mouse Cursor Control</td></tr> <tr><td>F</td><td>(0.25V - 4.75V) (4.75V - 0.25V)</td><td>V</td><td>Voltage regulator Unipolar</td></tr> <tr><td>G</td><td>(0.5V - 4.5V) (4.5V - 0.5V)</td><td>Y</td><td>Voltage regulator Bi-polar (±10 VDC)</td></tr> </table>	A	0V - 5V	H	(1V - 4V) (4V - 1V)	B	0.25V - 4.75V	N	CAN bus J1939	C	0.5V - 4.5V	P	CANopen	D	1V - 4V	U	USB Joystick Game Controller	E	(0 - 5V) (5 - 0V)	T	USB Mouse Cursor Control	F	(0.25V - 4.75V) (4.75V - 0.25V)	V	Voltage regulator Unipolar	G	(0.5V - 4.5V) (4.5V - 0.5V)	Y	Voltage regulator Bi-polar (±10 VDC)
A	0V - 5V	H	(1V - 4V) (4V - 1V)																														
B	0.25V - 4.75V	N	CAN bus J1939																														
C	0.5V - 4.5V	P	CANopen																														
D	1V - 4V	U	USB Joystick Game Controller																														
E	(0 - 5V) (5 - 0V)	T	USB Mouse Cursor Control																														
F	(0.25V - 4.75V) (4.75V - 0.25V)	V	Voltage regulator Unipolar																														
G	(0.5V - 4.5V) (4.5V - 0.5V)	Y	Voltage regulator Bi-polar (±10 VDC)																														

			A
Pushbutton specifications		HANDLE CONFIGURATION	SEALING
Electrical ratings:	@28VDC or 115 VAC, 60/400Hz	A No pushbutton	E Up to IP63 (above panel)*
Resistive:	5A	B One top pushbutton	N None
Inductive:	3A		
DWV:	1050Vrms		
Electrical life:	25,000 cycles		
Mechanical life:	1,000,000		
Operating temperature:	-40°C to +85°C (-40°F to 185°F)		
Operating force:	1.7lbf ± 0.5lb.		
Materials:			
Case & actuator:	Thermoplastic		
Terminals:	Brass with gold over silver		

*Above panel sealing up to IP63 (dependent on handle configuration)

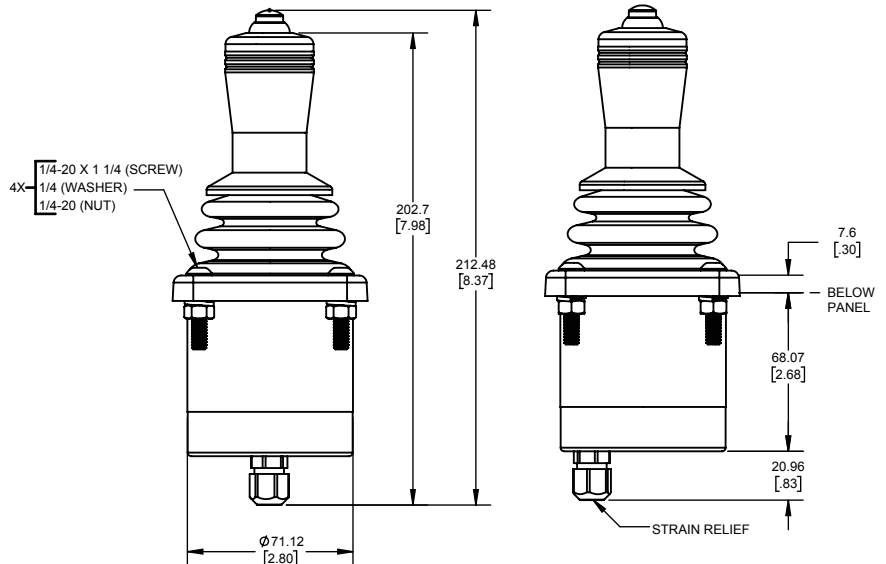

HJ series

Rugged hand grip controllers • non-contacting Hall effect technology

⚙️ BUILD YOUR PART NUMBER

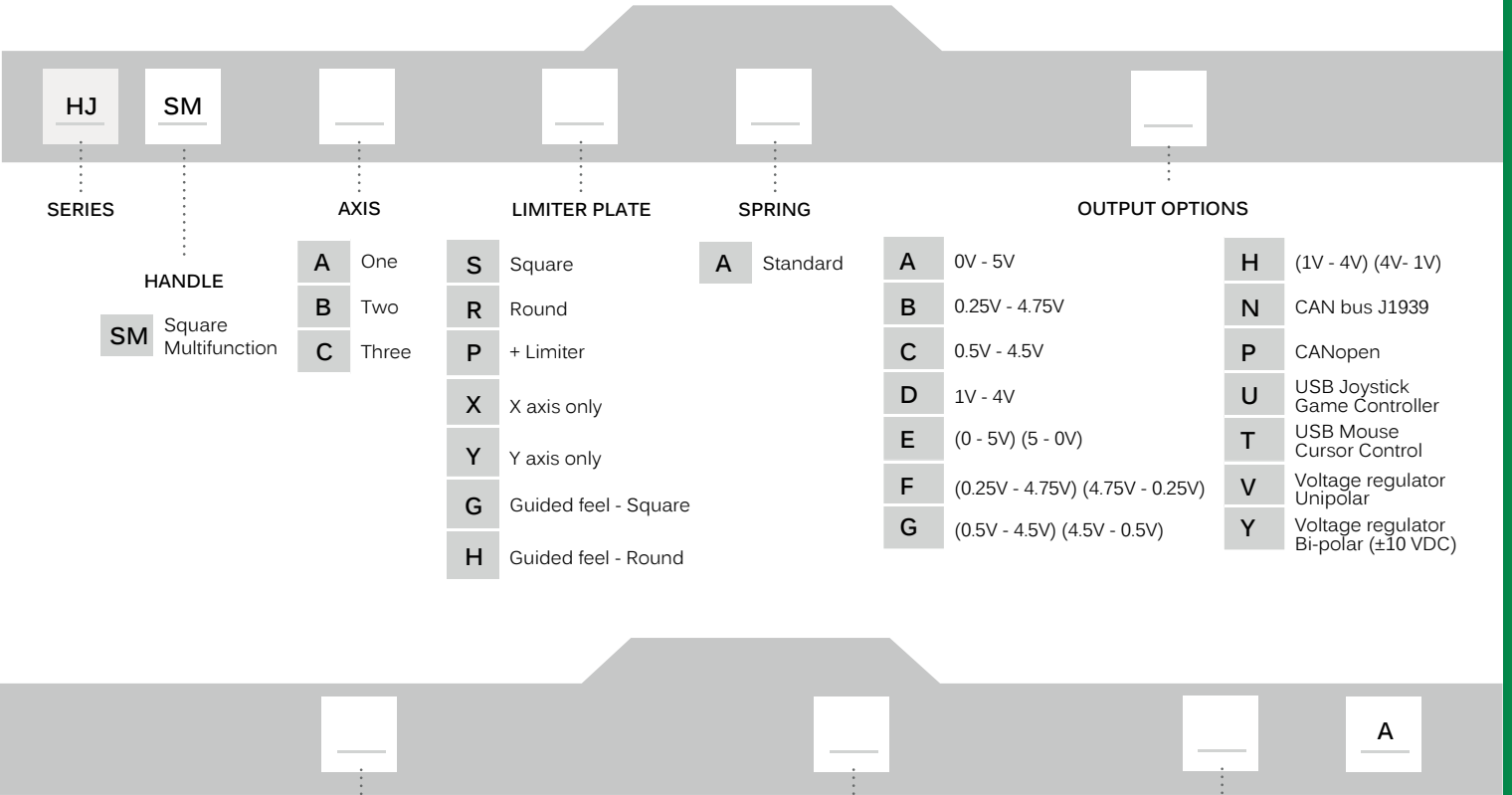

SERIES	HANDLE	AXIS	LIMITER PLATE	SPRING	OUTPUT OPTIONS
HJ	SM Square Multifunction	A One B Two C Three	S Square R Round P + Limiter X X axis only Y Y axis only G Guided feel - Square H Guided feel - Round	A Standard	A 0V - 5V B 0.25V - 4.75V C 0.5V - 4.5V D 1V - 4V E (0 - 5V) (5 - 0V) F (0.25V - 4.75V) (4.75V - 0.25V) G (0.5V - 4.5V) (4.5V - 0.5V)



INDEX TRIGGER	FACEPLATE	SEALING
Y Yes N No	A One pushbutton B Two pushbuttons C Three pushbuttons D Four pushbuttons E Five pushbuttons	E Up to IP63 (above panel)* N None

NOTES:
For more details about:
Thumbwheels - see CW series
Miniature joysticks - see TS series
Toggles - see MT series
Pushbuttons - see IM series

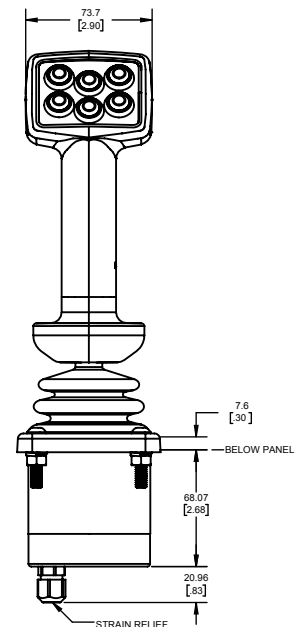
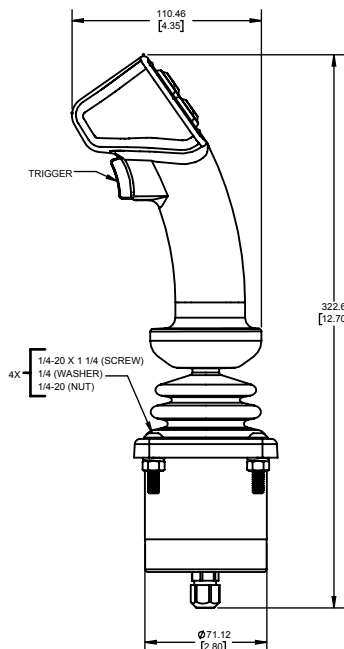

HJ series

Rugged hand grip controllers •
non-contacting Hall effect technology



HANDLE OPTIONS - FACEPLATES

Square Multifunction handle (SM)

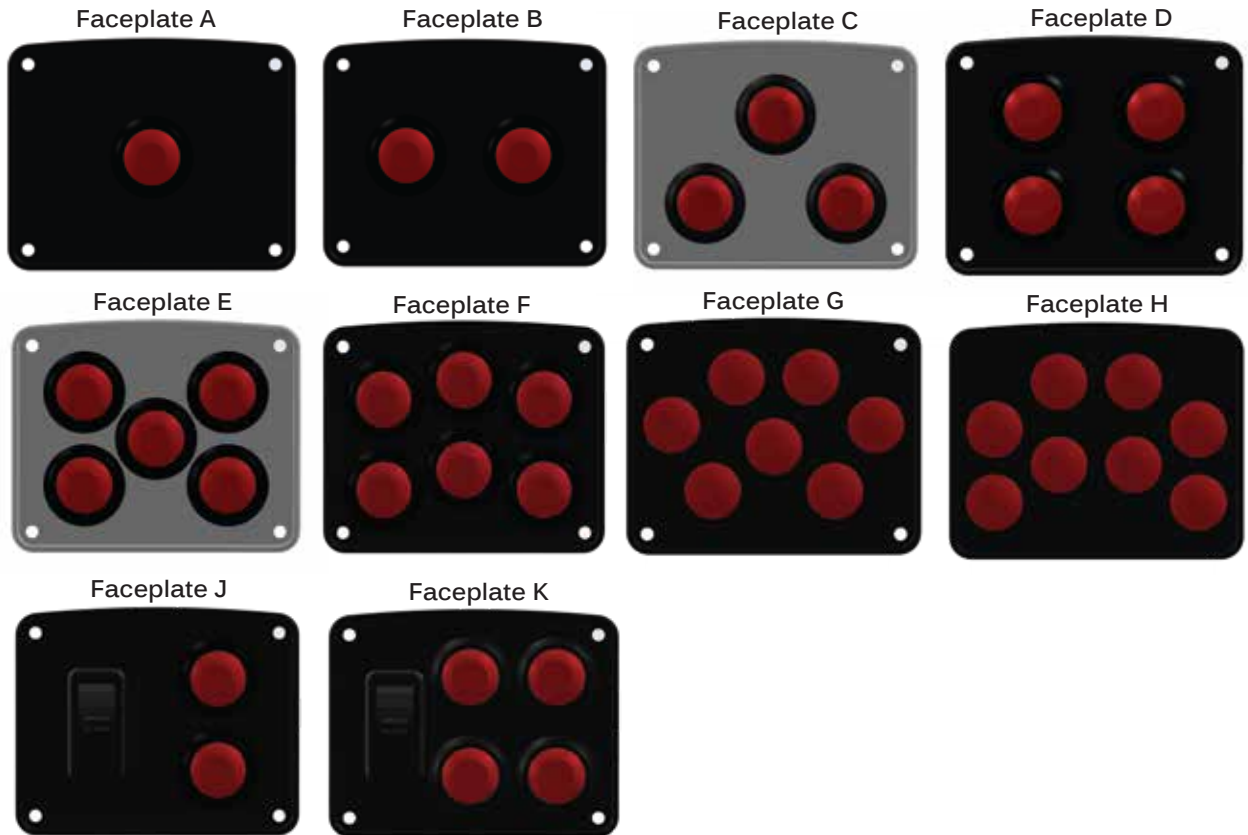

CW Series thumbwheel
Single axis proportional output
Spring return
P/N CWB1BK1AXX*A0

*voltage output = HJ series
joystick output



TS Series miniature joystick
Two axis proportional output
P/N TS1R2SXX*A

*voltage output = HJ series
joystick output



MT Series toggle switch
MOM-OFF-MOM
P/N MTG72AD2



IM Series pushbutton
Momentary & snap-action
Sealed
P/N IMR7Z462

HJ series

Rugged hand grip controllers •
non-contacting Hall effect technology

⚙️ BUILD YOUR PART NUMBER

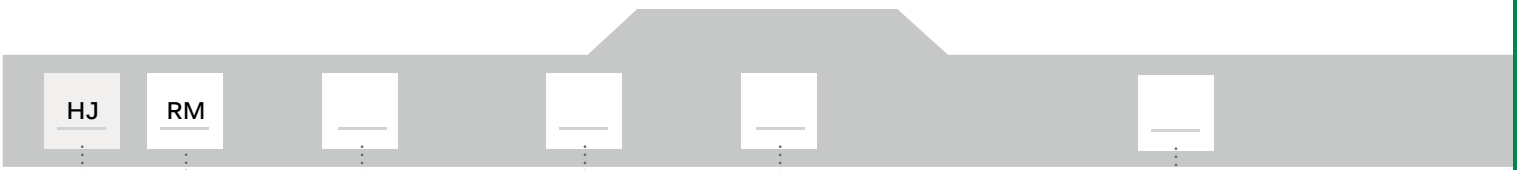

SERIES	HANDLE	AXIS	LIMITER PLATE	SPRING	OUTPUT OPTIONS
HJ	RM Round Multifunction	A One B Two C Three	S Square R Round P + Limiter X X axis only Y Y axis only G Guided feel - Square H Guided feel - Round	A Standard	A 0V - 5V B 0.25V - 4.75V C 0.5V - 4.5V D 1V - 4V E (0 - 5V) (5 - 0V) F (0.25V - 4.75V) (4.75V - 0.25V) G (0.5V - 4.5V) (4.5V - 0.5V)
					H (1V - 4V) (4V - 1V) N CAN bus J1939 P CANopen U USB Joystick Game Controller T USB Mouse Cursor Control V Voltage regulator Unipolar Y Voltage regulator Bi-polar (±10 VDC)



OPERATOR PRESENCE	INDEX TRIGGER	FACEPLATE	SEALING
Y Yes N No	Y Yes N No G Trigger with guard	A Two pushbuttons B Four pushbuttons C Five pushbuttons D Six pushbuttons E Eight pushbuttons F Toggle & 2 pushbuttons G Two pushbuttons and toggle H Toggle, thumbwheel and two pushbuttons	J Two pushbuttons, thumbwheel and toggle K Two axis miniature joystick and two pushbuttons L Toggle, miniature joystick and two pushbuttons M Two toggles N Two pushbuttons, miniature joystick and thumbwheel P Four pushbuttons and miniature joystick Q Two pushbuttons, miniature joystick and toggle R Thumbwheel, miniature joystick & 2 pushbuttons
			E Up to IP63 (above panel)* N None *Above panel sealing up to IP63 (dependent on handle configuration)

NOTES:
For more details about:
Thumbwheels - see CW series
Miniature joysticks - see TS series
Toggles - see MT series
Pushbuttons - see IM series

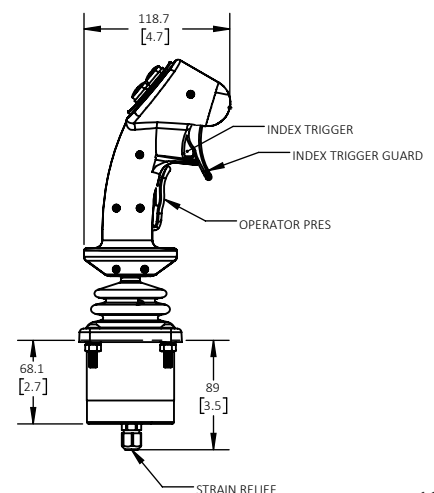
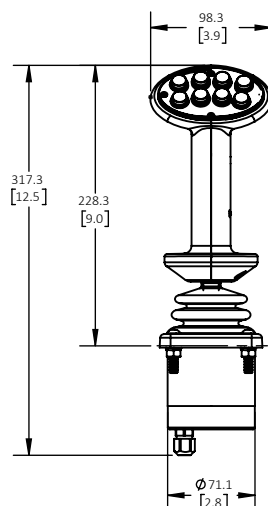

HJ series

Rugged hand grip controllers •
non-contacting Hall effect technology



HANDLE OPTIONS - FACEPLATES

Round Multifunction handle (RM)

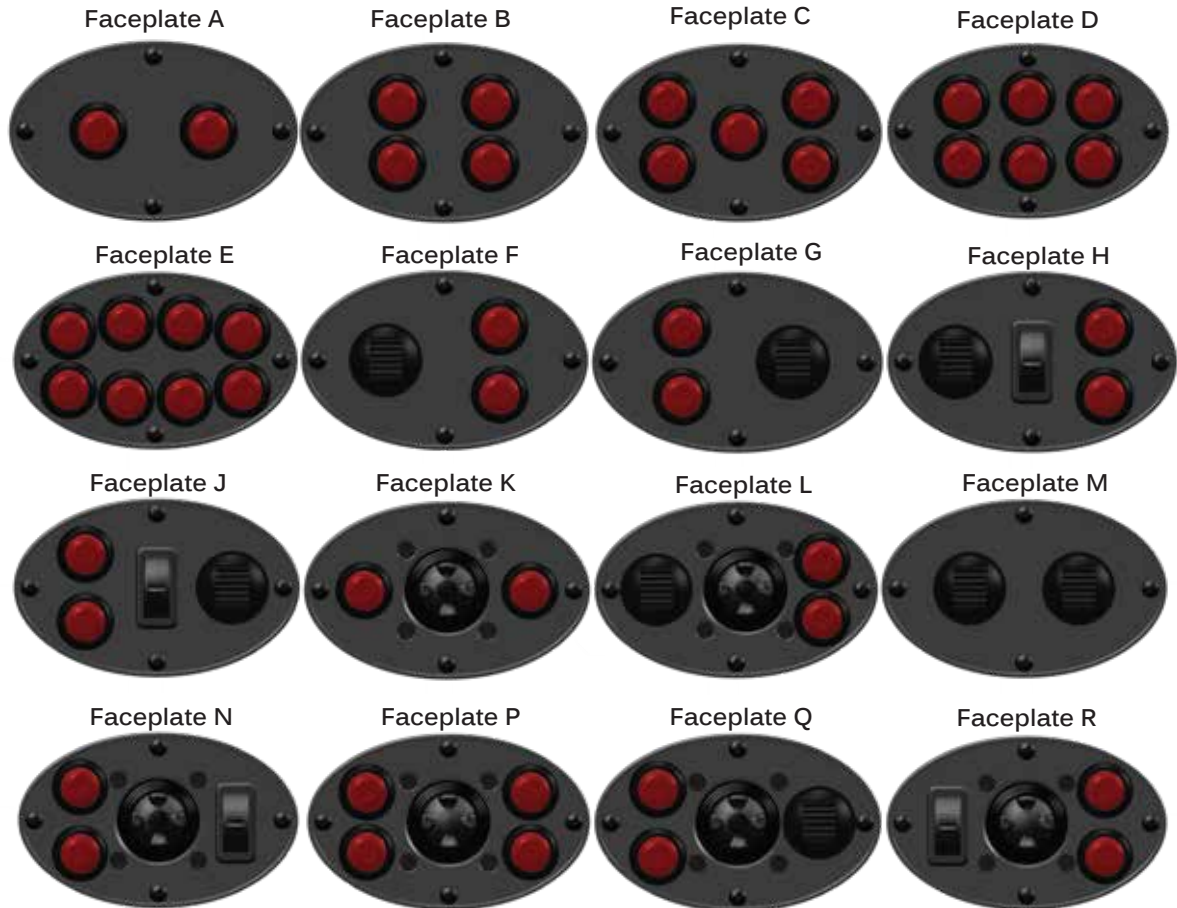

CW Series thumbwheel

Single axis proportional output
Spring return
P/N CWB1BK1AXX*A0

*voltage output = HJ series
joystick output



TS Series miniature joystick

Two axis proportional output
P/N TS1R2SXX*A

*voltage output = HJ series
joystick output



MT Series toggle switch

MOM-OFF-MOM
P/N MTG72AD2



IM Series pushbutton

Momentary & snap-action
Sealed
P/N IMR7Z462